





www.stiweb.com

OPERATION MANUAL

Temperature Input Transmitters and Monitors

Revision B 08-15-2013

CMCP560(A)
CMCP565(A)
CMCP570(A)

 <p>MET[®] c us</p> <p>Hazardous Location Safety E112798 UL1604, CSA C22.2 No 213 Cl 1, Div 2, Grp B,C,D 24 VDC, 50 mA Max</p>	<p>NOTICE! This equipment is suitable for use in Class I, Division 2, Groups B-D</p>	
---	---	---

IMPORTANT!
After installation of this unit, no connections are to be made or broken while any connection on the unit is powered up.

Après l'installation de cette unité, pas de connexions doivent être faites ou cassé pendant toute connexion de l'appareil est sous tension.

Table of Contents

1.0	General:
1.1	Model Description
1.2	Power
1.3	Opening the Case
1.4	Dimensions and Mounting
2.0	Transmitter:
2.1	Transducer
2.2	Transducer Cable
2.3	Transducer OK Circuit
2.4	Full Scale Range
2.5	4-20 mA Output
2.6	Buffered Output
3.0	Monitor Alarm Module:
3.1	Alert and Danger Setpoints
3.2	Alert and Danger Delay Adjustment
3.3	Latching/Non-Latching Alarms
3.4	Trip Multiply
3.5	Alarm Relays
3.6	Alarm Module Jumper Selection
4.0	Test and Calibration Setup:
4.1	CMCP560
4.2	CMCP565
4.3	CMCP570

1.0 General

1.1 Model Description:

The CMCP500 Series Temperature Transmitters are 4-20mA Output Transmitters. They are ordered and factory configured for use with a Solid State Temperature Sensor, RTD or Thermocouple. The input signal is processed to determine its overall temperature in the selected engineering terms. The output is a standard 4-20mA current proportional to the full scale range. The 4-20 mA output is suitable for direct connection to a Programmable Logic Controller (PLC) or Distributed Control System (DCS). The CMCP570 provides buffered access to the transducer signal for use with portable instruments via a BNC connector on the front.

The CMCP500 Series Transmitters can be also ordered as a standalone Monitor by adding the suffix "A" to the basic model number, i.e.: CMCP5XXA. When ordered in this configuration, the unit includes an alarm module that provides independent set point alarms for both ALERT (A) and DANGER (D) levels. Each set point has a corresponding adjustment potentiometer, a LED indicator on the alarm module front panel, and an output relay that can be configured for either latching or non-latching operation. The alarm LED will turn "ON" and the corresponding relay will actuate whenever the temperature levels exceed the corresponding set point for more than a preset (jumper selectable) delay time. The alarm module has a front panel accessible BNC connector and associated selector switch for reading the current temperature level (CV) or alarm set points (A or D) with a standard digital volt-meter. The alarm module also provides a transducer "OK" relay, and a Trip-Multiply function. Trip multiply allows the alarm levels to be temporarily increased by a factor of two or three during periods of known short term high temperatures. Both monitors and transmitters mount on standard DIN rail.

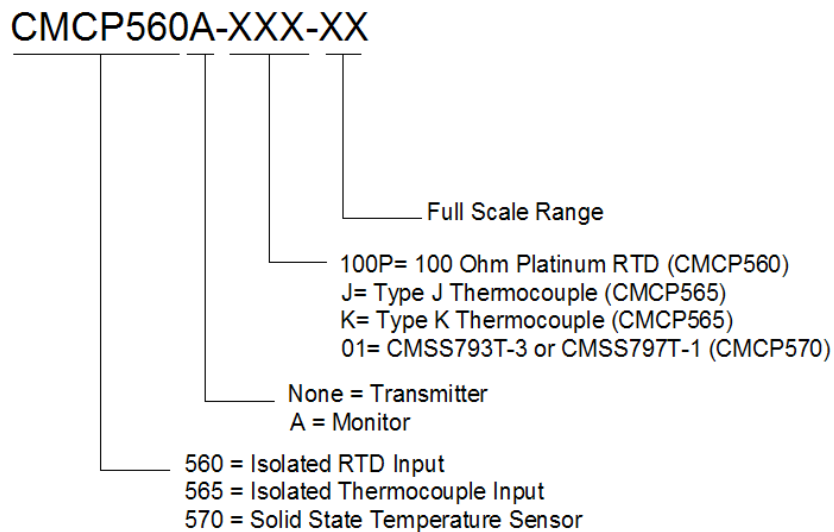

1.2 Power:

The CMCP500 Series require externally supplied DC power. The power supply should have a nominal output of +24Vdc and be capable of supplying a minimum of 100mA for each CMCP500 Series Transmitter in the system, or 200 mA for each CMCP500A Series Monitor in the system. A power-supply dedicated to the temperature monitoring system is recommended. It is also recommended that connections between the power-supply and the monitors be made with twisted-shielded instrument cable. The cable shield should float at the monitor / transmitter installation, and connect to common at the power-supply / system common end only. The CMCP500 Series Transmitters and Monitors regulate dc power internally to prevent a fault on the output of one channel from affecting other channels. When power is first applied to a monitor or transmitter after connecting the transducer, there will be a delay of approximately 30 seconds before the "OK" LED turns "ON".

1.3 Opening the Case:

Opening the case is best done with a small flat-blade screwdriver. On transmitters (1" wide units) insert the tip of the screwdriver between the right-side cover (as viewed from the front of the unit) and the DIN rail mounting foot at the back of the unit and gently leverage the blade to begin separating the cover from the rest of the unit. Carefully work your way around to the front of the unit to complete removal of the cover, exposing the circuit board components. On Monitors (1.6" wide units), you must first CAREFULLY separate the two halves of the unit at the center. The sides do not need to be removed. This is done by working the screwdriver around the middle of the unit in the same general manner described above. As the two halves start to become separated, you will see that they are still attached by a short ribbon cable inside. This cable can be carefully removed by pulling it away from the left hand side of the unit. The cable stays with the right hand side permanently. **CAUTION:** When re-installing this cable, make sure it is properly connected to the mating connector, and that the bend in the cable goes towards the front panel side of the unit. IF THE UNIT IS CLOSED WITH THE BEND TOWARDS THE BACK, THE RIBBON CABLE CAN BE DAMAGED. Also, make sure the ribbon cables' connector does not catch on the relays when pressing the unit back together.

1.4 Dimensions and Mounting:

CMCP500 Series Transmitters and Monitors are designed to be mounted on Din Standard 35 mm "T" Rail or "G" Rail. They simply snap in place by aligning the top of the mount on the track and pressing down. To remove insert a screwdriver in the tab at the bottom and pull down and out slightly.

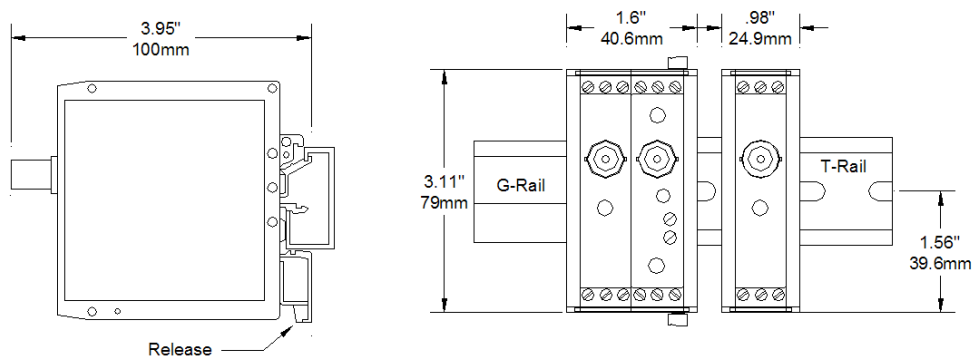

2.0 Transmitter

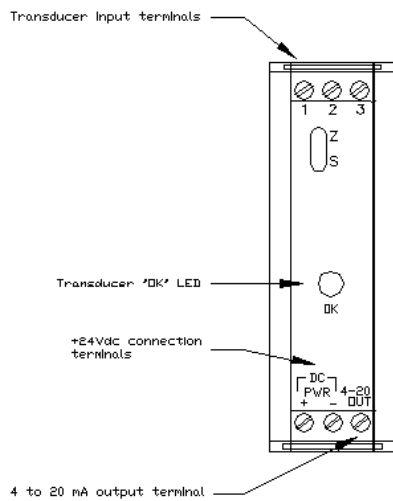

CMCP560 and CMCP565

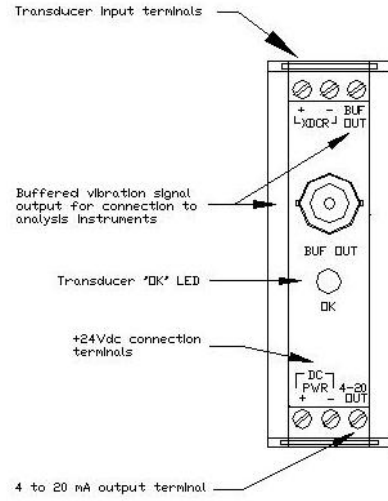

CMCP570

2.1 Transducer:

The CMCP500 Series is factory configured for use with one of four transducer types. The specific type is identified by a dash number immediately following the basic part number on the side label.

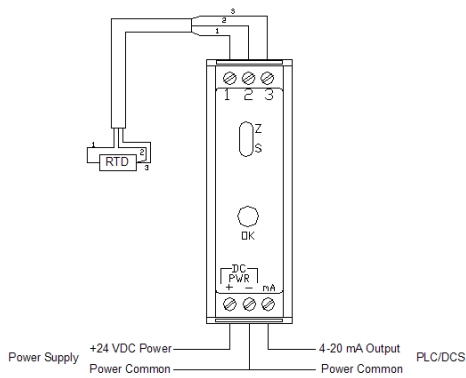

CMCP560

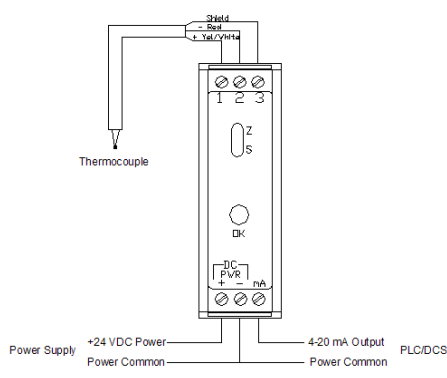

CMCP565

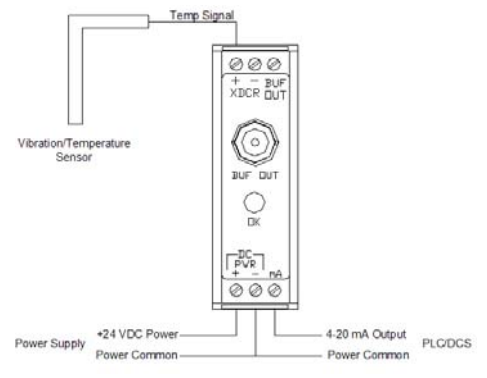

CMCP570

2.2 Transducer Cable:

It is strongly recommended that the transmitter / monitor be mounted as close as practical to the associated sensor. This will help to minimize interference from the external electro-magnetic noise sources (EMI). A shielded, properly installed transducer cable is recommended to obtain proper and reliable operation. The cable should be connected to the system common on the transmitter side. See chart below for proper shield landing.

Model Number	Terminal
CMCP560 (A)	3
CMCP565(A)	3
CMCP570(A)	xdcr -

Note: The CMCP570 (A) provides power for the temperature transducer via a nominal 4.4mA constant current source.

2.3 Transducer OK Circuit:

The CMCP500 Series incorporates a transducer "OK" circuit. This feature continuously monitors the transducer bias and signal voltage. If this voltage exceeds (over or under) pre-set limits, the 4-20 mA output current is reduced to less than 2 mA (typically 0 mA) to allow detection of the fault condition at the associated PLC or DCS system. A green "OK" LED on the front of the unit ("ON" in an "OK" condition) turns "OFF" to provide a local indication of the fault condition. This circuit will effectively detect open, shorted, or reversed transducer connections. If a fault is detected that subsequently is repaired or goes away, there will be a delay of approximately 30 seconds before the unit returns to the "OK" condition and the "OK" LED turns back "ON". The detected fault will also disable the "ALERT" and "DANGER" alarms/relays until the fault is removed and an "OK" condition exists.

2.4 Full Scale Range:

The CMCP500 Series is supplied factory calibrated for the full-scale range specified at the time of order. The factory calibrated range is listed on the side label as a dash number. Custom ranges are available.

Range	CMCP560	CMCP656	CMCP570
-01	0-250 Deg. F	0-250 Deg. F	0-250 Deg. F
-02	0-350 Deg. F	0-350 Deg. F	N/A
-03	0-500 Deg. F	0-500 Deg. F	N/A
-51	0-120 Deg. C	0-120 Deg. C	0-120 Deg. C
-52	0-175 Deg. C	0-175 Deg. C	N/A
-53	0-260 Deg. C	0-260 Deg. C	N/A

2.5 4-20 mA Output:

The primary output of the monitor/transmitter is the 4-20 mA current output which is proportional to the full scale range of the unit. IE: If the range is 0 – 250 Deg F then 4 mA indicates a reading of 0 Degrees F and 20 mA indicates a reading of 250 Degrees F. This output is intended to drive a maximum resistive load of 600 Ohms with respect to system common at the PLC/DCS input. A precision 250 Ohm resistor is the recommended load if the IO Module is not equipped. This will convert the 4-20 mA current reading into a 1-5 Vdc reading for the PLC/DCS. A short to ground (common) on this output *will not* damage it.

2.6 Buffered Output:

The CMCP570(A) provides buffered access to a 0-5Vdc, temperature proportional signal via a BNC connector on the front of the unit. The buffered output signal is also available on a screw terminal at the top

of the unit.

3.0 Monitor Alarm Module (If Equipped):

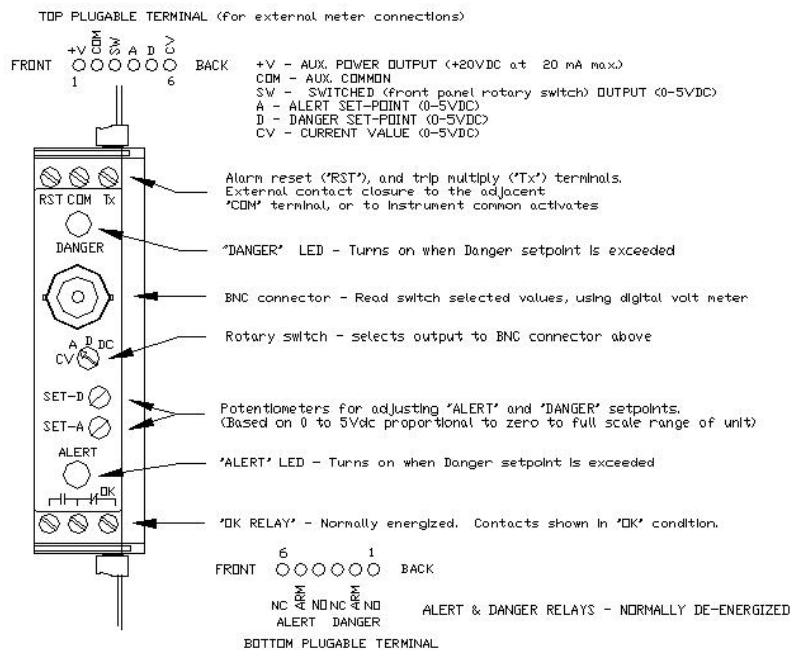

3.1 Alert and Danger Alarm Set-Point Adjustment:

The Alert and Danger alarm set-points can be independently set in the field by turning the front panel selector switch to the associated position (A or D) and adjusting the associated front-panel potentiometer until the correct DC voltage is measured at the BNC connector located directly above the selector switch. Adjusting the set-point requires the use of a digital volt-meter, knowledge of the full scale range of the monitor, and the desired set-point as a percentage of the full scale range. The voltage measured at the BNC will vary between 0 Vdc and 5 Vdc, corresponding to 0 to Full-scale. i.e.: 2.5 Vdc represents 50% of full scale, 3.75 Vdc represents 75% of full scale. To calculate the required set point voltage if the unit is not equipped with a display, use the equation, $5(.xx)$ where .xx is the desired percentage expressed as a decimal fraction of the full scale range. i.e.: $5(.60) = 3.00$ Vdc for a set-point of 60% of the full scale range. Turning the potentiometer clockwise increases the set point voltage.

3.2 Alert and Danger Alarm Delay Adjustment:

The Alert and Danger alarm delays can be independently set by internal jumper selection to 0.1, 1.0, 3.0, 6.0, or 10.0 seconds. The purpose of the delay is to reduce nuisance alarms caused by external electrical noise and/or transient temperature events. Both the Alert and Danger delay are factory set to the 3 second position. To change the delay, open the unit and move the delay jumpers to the proper position (Refer to Section 3.6 "Alarm Module Jumper Settings").

3.3 Latching/Non-Latching Alarms:

The Alert and Danger alarms are factory set for NON-LATCHING operation. This means that whenever the temperature level drops below the associated set-point for more than about 1 second, the associated relay will de-energize and the alarm LED will turn off. The alarms can also be set for LATCHING operation by installing shunts on jumpers E1 and E2 respectively on the Alarm module circuit board (See: CMCP500 SERIES ALARM MODULE JUMPER LOCATIONS, at the back of this manual). Latched alarms may be reset by closing the RESET (RST) and COMMON (COM) contacts at the top of the unit. This may be done with an external switch, dry contact relay, or by shorting the terminals together by hand. DO NOT APPLY VOLTAGE TO EITHER THE "RST" or "COM" TERMINALS. If several monitors are mounted together, the

"RST" terminals may be daisy-chained together.

3.4 Trip Multiply:

The alarm module provides a trip multiply feature. This feature allows the user to temporarily double (standard) or triple (jumper selectable) the normal set points during periods of normal high temperature. To actuate the trip multiply feature, the Tx terminal at the top of the alarm module must be closed to the adjacent "COM" terminal. This may be done with an external switch, dry contact relay, or by shorting the terminals together by hand. **DO NOT APPLY VOLTAGE TO EITHER THE "Tx" or "COM" TERMINALS.** If several monitors are mounted together, the "Tx" terminals may be daisy-chained together and switched to "COM" (system common) as a group.

3.5 Alarm Relays:

The Alert Danger and OK relays are independent, single-pole-double throw relays. NO, ARM, and NC contacts are available via plugable screw-connector at the bottom of the monitor. OK relay contacts are available on fixed screw terminals at the bottom front of the alarm module (Refer to Section 3.0 "Monitor Alarm Module"). Relay contacts are rated 5 Amps at 30 Vdc or 125 Vac, resistive load. This rating includes any inrush current that the load draws. For loads that are not purely resistive the contact switching capability will need to be considered carefully in terms of this inrush current. The entire subject of relay application is too large to address here, so the user is cautioned to use care in the application of the relays. The factory intended purpose of providing relay contacts is to operate relatively low power alarm annunciators, act as a dry or low dc voltage contact closure input to other systems, or act to actuate an appropriately sized slave relay for larger loads such as shutting down a motor. Relays are socketed and can be replaced.

3.6 Alarm Module Jumper Selection:

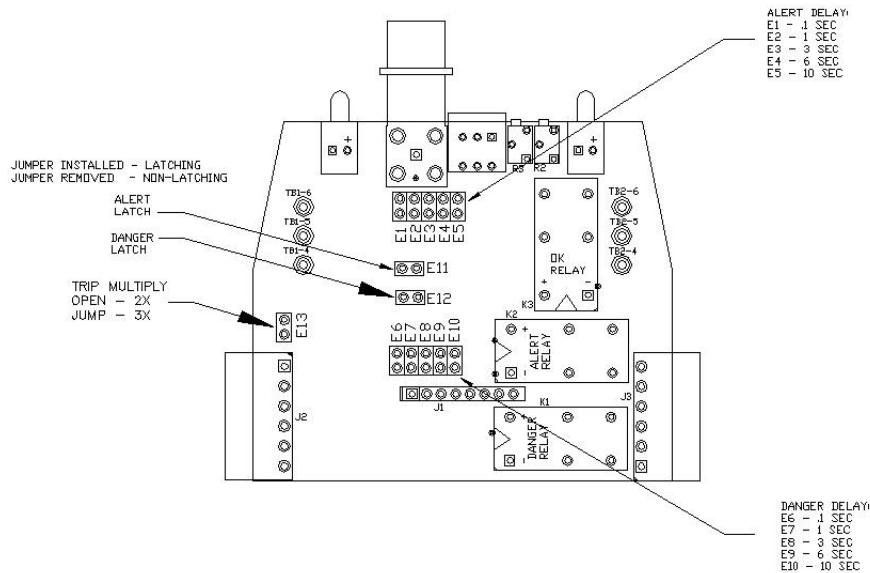

4.0 Test and Calibration:

The test equipment listed below is required to perform Zero and span calibration:

CMCP560

- (1) +24 Vdc linear regulated power supply
- (1) 100 Ohm platinum RTD simulator, or precision resistors.
- (1) 4.5 digit DC/True RMS reading digital volt/current meter. Fluke 87 or better

CMCP565

- (1) +24 Vdc linear regulated power supply
- (1) Precision thermocouple simulator
- (1) 4.5 digit DC/True RMS reading digital volt/current meter. Fluke 87 or better

CMCP570

- (1) +24 Vdc linear regulated power supply
- (1) Variable DC power supply with floating output
- (1) 4.5 digit DC/True RMS reading digital volt/current meter. Fluke 87 or better

4.1 CMCP560 Test and Calibration:

Zero Calibration:

The Zero output has been factory calibrated for the value indicated on the side label. Small calibration adjustments can be made using the ZERO pot located on the front of the unit.

1. Connect the RTD simulator to the input terminals 1 and 2 and set it for the zero-scale temperature.
2. Connect a jumper from input terminal 2 to input terminal 3.
3. Adjust the ZERO potentiometer (marked Z) until the output is 4.00 mA +/- .01 mA.

Full-Scale Calibration:

The full-scale output has been factory calibrated for the value indicated on the side label. Small calibration adjustments can be made using the SPAN pot located on the front of the unit.

1. Connect the RTD simulator to input terminals 1 and 2 and set it for the full-scale temperature.
2. Connect a jumper from input terminal 2 to input terminal 3.
3. Adjust the ZERO potentiometer (marked S) until the output is 4.00 mA +/- .01 mA.

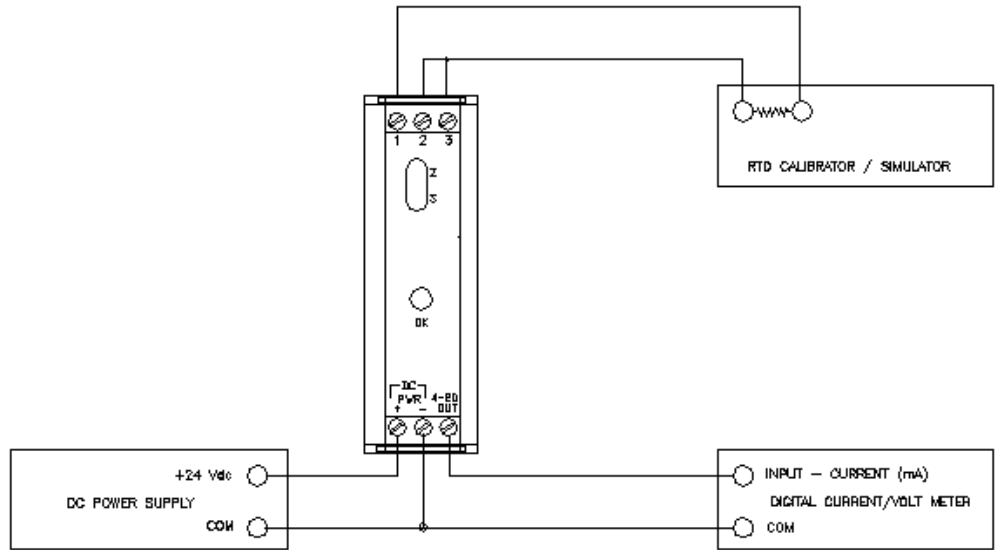

CMCP560 Test Setup

4.2 CMCP565 Test and Calibration:

Zero Calibration:

The Zero output has been factory calibrated for the value indicated on the side label. Small calibration adjustments can be made using the ZERO pot located on the front of the unit.

1. Connect the TC simulator to the input terminals 1 and 2 and set it for the zero-scale temperature.
2. Adjust the ZERO potentiometer (marked Z) until the output is 4.00 mA +/- .01 mA.

Full-Scale Calibration:

The full-scale output has been factory calibrated for the value indicated on the side label. Small calibration adjustments can be made using the SPAN pot located on the front of the unit.

1. Connect the TC simulator to input terminals 1 and 2 and set it for the full-scale temperature.
2. Adjust the ZERO potentiometer (marked S) until the output is 4.00 mA +/- .01 mA.

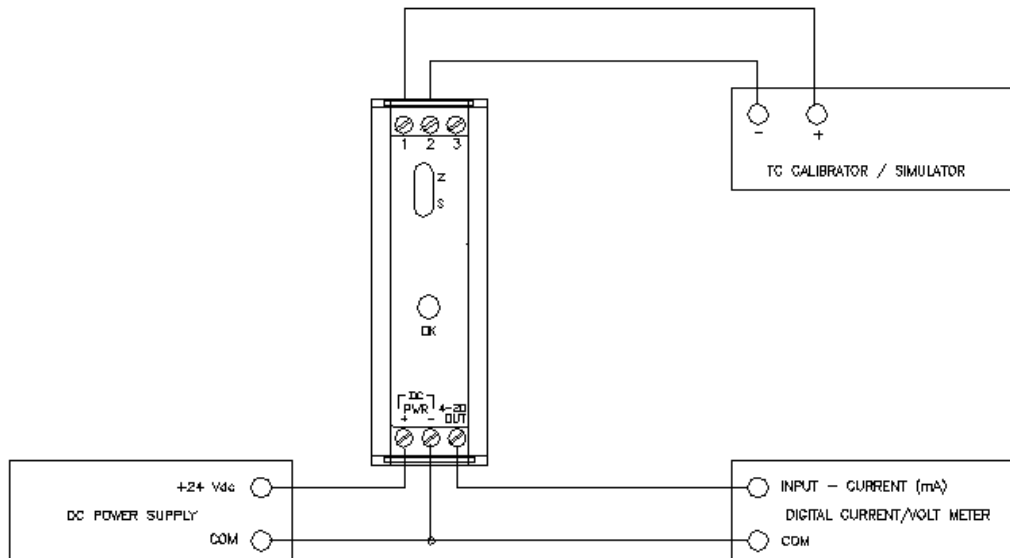

CMCP565 Test Setup

4.3 CMCP570 Test and Calibration:

Zero Calibration:

The Zero output has been factory calibrated for the value indicated on the side label. Small calibration adjustments can be made using the ZERO pot located on the front of the unit.

1. Connect the variable dc power supply to input terminals and set it for the corresponding voltage for Zero Scale Temperature.
2. Adjust the internal potentiometer (R8) until the output is 4.00 mA +/- .01 mA.

Full-Scale Calibration:

The full-scale output has been factory calibrated for the value indicated on the side label. Small calibration adjustments can be made using the SPAN pot located on the front of the unit.

1. Connect the variable dc power supply to input terminals and set it for the corresponding voltage for Full Scale Temperature.
2. Adjust the internal potentiometer (R12) until the output is 4.00 mA +/- .01 mA.

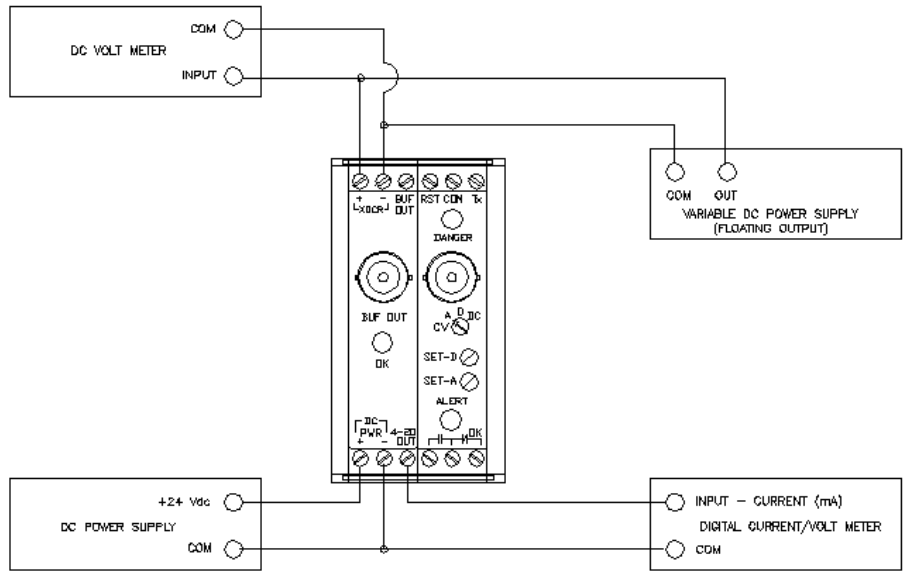

CMCP570 Test Setup